

Guide to Safe Use of Overhead Travelling Cranes, Gantry Cranes, Jib Cranes and Hoists



Contents

1.	Introduction	03
1.1	Purpose	03
1.2	Application	03
2.	Common Accidents	04
3.	Key Personnel Involved in Lifting Operations	05
3.1	Owner / Occupier	05
3.2	Lifting Supervisor	05
3.3	Crane Operator	05
4.	Visual Checks	06
5.	Rigging Methods	11
6.	Operational Safety	13
6.1	Safety Considerations	13
6.2	Tandem Lifting	18
6.3	Maintenance	18
7.	Use of Special Lifting Attachments	19
8.	Environmental Conditions	20
8.1	Rains	20
8.2	Thunderstorms	20
8.3	Strong Winds	20
9.	Documentation	21
10.	References	22
11.	Annexes	23
	Annex 1: Standard Hand Signals For Controlling Overhead and Gantry Cranes	23
	Annex 2: Lifting Gear (LG) and Lifting Appliances (LA)	24
12.	Acknowledgements	26

1. Introduction

Overhead Travelling Cranes, Gantry Cranes, Jib Cranes and Monorail Hoists are used widely for material handling. Safe operation of such cranes requires operators to have the knowledge and competence to avoid accident.

1.1 Purpose

The purpose of this guide is to raise awareness of the hazards in lifting operations and to provide the basic knowledge in the safe operation of overhead travelling cranes, gantry cranes, jib cranes and hoists.

1.2 Application

This guide is intended to be used by crane operators and supervisors to promote safe lifting operations in the handling of Overhead Travelling Cranes, Gantry Cranes, Jib Cranes and Hoists. Please see Figure 1 for examples of overhead travelling cranes, gantry cranes, jib cranes and hoists.



Example of an Overhead Travelling Crane



Example of a Jib Crane



Example of a Gantry Crane

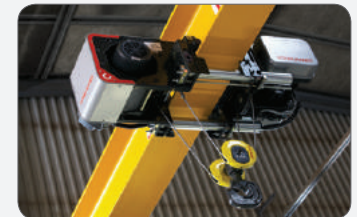

Example of a Powered Hoist

Figure 1: Examples of overhead travelling cranes, gantry cranes, jib cranes and hoists.

2. Common Accidents

Most accidents related to gantry cranes, overhead travelling cranes, jib cranes and hoists occur during the lifting activity. The consequences of an accident can be serious, and fatal at times. Adopting the right method and using the right equipment will greatly minimise potential accidents during lifting operations. See Figure 2 for common accidents.

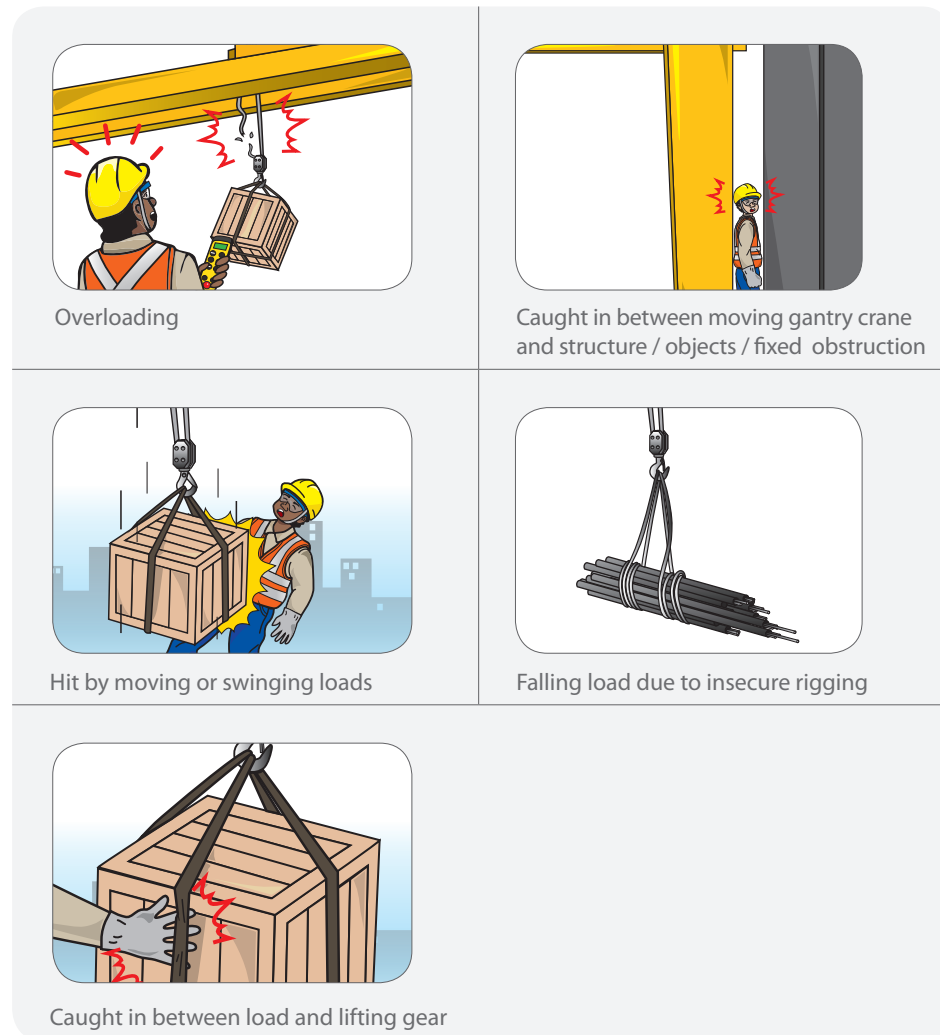

Figure 2: Common accidents

3. Key Personnel Involved in Lifting Operations

The key personnel in lifting operations includes the following duty holders:

3.1 Owner / Occupier

- Occupier needs to ensure that the crane is tested by an Authorised Examiner (AE). The Authorised Examiner must conduct a thorough examination of the crane every year and issue a certificate that shows that the crane is safe to be used. A load test must be conducted every 4 years.
- Crane owner shall ensure that the crane operator is trained in the safe operation of the crane
- Crane owner must ensure that the crane is in good mechanical construction and maintained properly.

3.2 Lifting Supervisor

- Lifting Supervisor needs to co-ordinate all lifting activities.
- Co-ordination can be achieved through the proper briefing of the lifting plan to all relevant personnel such as the lifting team and co-workers affected by the lifting operations.

3.3 Crane Operator

- Crane operator is required to be trained and deemed competent in the operation of the crane.

4. Visual Checks

Note: Lifting equipment include lifting machines and lifting gears.

The following required checks are non-exhaustive. Crane operators must conduct visual checks to ensure the crane is in working condition, and test all limiting and indicating devices under no load condition before the start of every shift. All observations must be recorded in a log book or organisation’s checklist(s) according to work processes at the workplace. Report any defects found to your supervisor immediately. See Figure 4 for types of visual checks.

The occupier must ensure that the crane has a valid Test Certificate issued by an AE and accompanied stickers / tags. See Figure 3 for Test Certificate and tags.



Certificate of Test / Thorough Visual Examination of Lifting Equipment (LE)

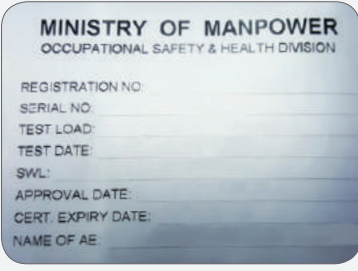

Sticker for Lifting Machine (LM)



Tag for Lifting Gear (LG) and Lifting Appliances (LA)

Figure 3: Test certificates and tags.

Types of visual checks

Check the crane for:

- Oil leakage; and
- Any unusual vibration or sound.

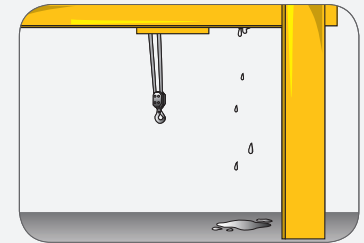

Check that hoist is in proper working condition, and all motion indicators on the pendant control correspond with control device marking.

Always familiarise yourself with the controls as pendant controls can differ from one another.

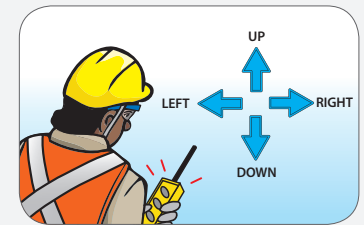

Ensure all hoist limit switches, travel limit switches and indicating devices are in good working condition.

A Crane may also be provided with any or a combination of the following types of indicators:

- Load indicator;
- Working space limiter;
- Anti-collision device; and
- Crane Motion indicator (Audible and visual).



Check hook block to make sure it is in good working condition.

Check that the safety latch is able to spring back.

There should be no illegal modification to the hook.

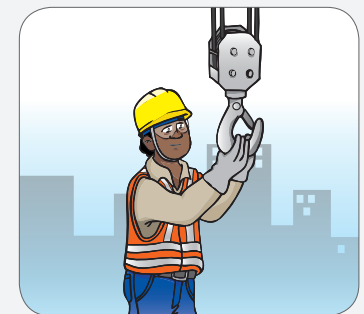

Inspect the hook for nicks, gouges, deformation of the throat opening, wear on saddle or load bearing point, and twisting.

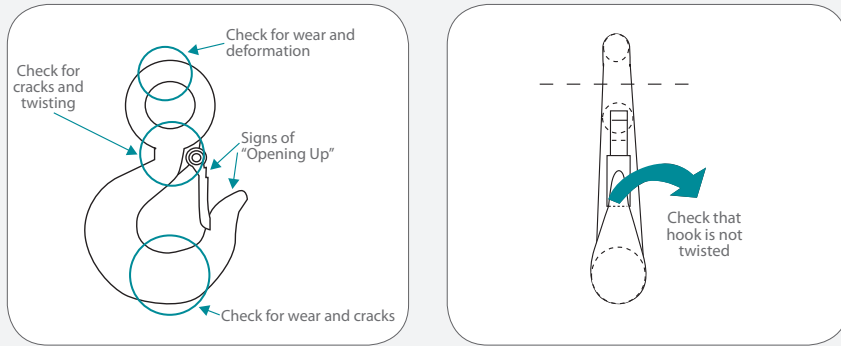

Check shackles for any defects and make sure they are in good working condition.

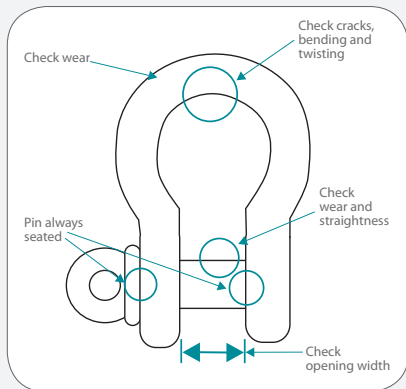

Check wire ropes for any deformation or damages such as:

- Broken wires;
- Strand distortion;
- Kinks;
- Excessive wear;
- Bird caging;
- Crushing;
- Rusty; and
- Stretching.

Images (Strand protrusion or distortion, Broken wire and Rusty) are reproduced from ISO 4309:2010 with permission from the International Organisation for Standardization (ISO). All rights reserved by ISO.



Wire rope kinks

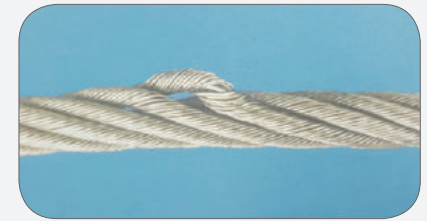

Strand protrusion or distortion



Rope bulging

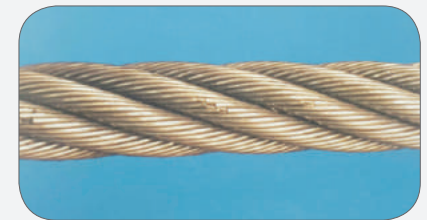

Broken wire



Bird cage



Rusty

Check chains and chain slings for any defect. Make a link-by-link inspection and report the defect if the following conditions are:

- Cut, nicked, cracked, gouged, burned, or corrosion pitted;
- Twisted or bent; and
- Stretched (Links tend to close up and get longer).

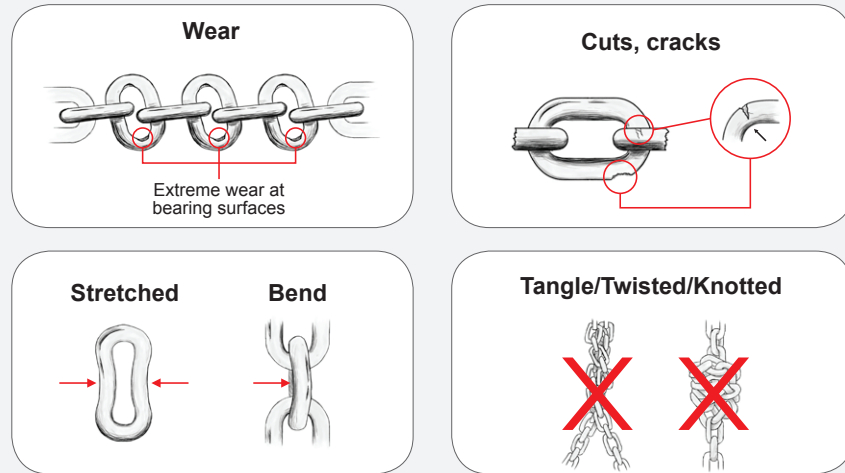

Check web slings for any defect. Damage is usually easy to detect. Report to the Supervisor if there are:

- Cuts, holes, tear;
 - Frays, broken stitching, worn eyes and worn or distorted fittings ; and
 - Burns from acid, caustics or heat.
- These are for immediate replacement.



Figure 4: Types of visual checks.

5. Rigging Methods

Accidents due to rigging can often be traced back to a rigging knowledge by the rigger or the operator's assistant. A safe rigging operation requires the rigger to know the following:

- the weight of the load including Lifting Gear;
- the capacity of the lifting or hoisting devices; and
- the safe working load limit of the LG.

When the weight and capacities are established, the rigger must then use the proper methods to rig the load so that it is stable.

Important points to note while rigging

Check on Sling Angle

- Ensure that the sling angle is always greater than 45°.
- When the horizontal distance between the attachment points on the load is less than the length of the shortest sling leg, then the angle is greater than 60° and generally safe.

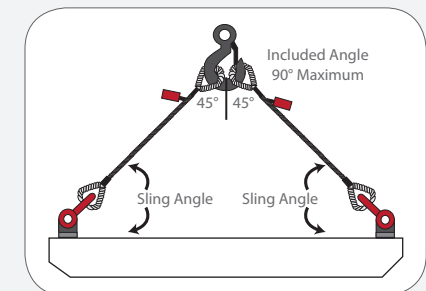
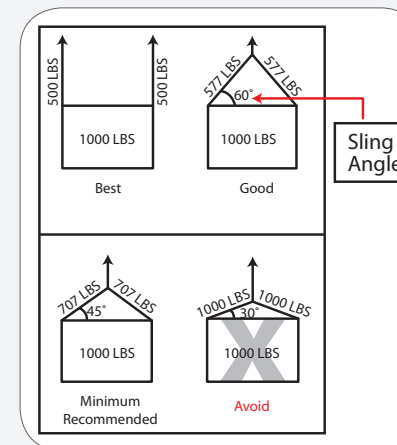

Multi-leg slings

- For slings with more than two legs and a rigid load, it is possible for some of the legs to take the full load while the others merely balance it.
- As a result, when lifting rigid objects with three- or four-leg bridle slings, make sure that at least two of the legs alone can support the total load. In other words, consider multi-leg slings used on a rigid load as having only two legs.

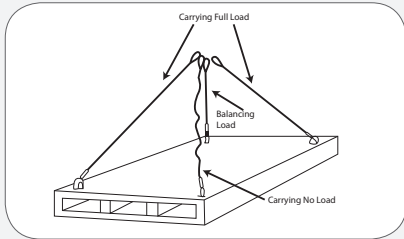

Centre of Gravity (CG)

It is always important to rig the load so that it is stable. The load's centre of gravity must be directly under the main hook and below the lowest sling attachment point before the load is lifted

- Ensure (CG) is directly under the hook for stability of load

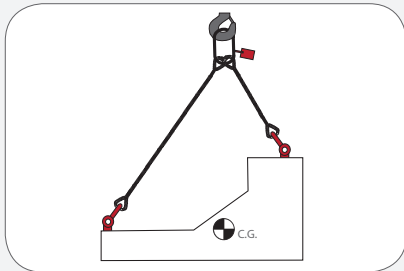

Rig with correct lifting gears

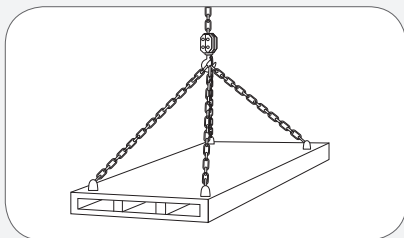

Figure 5: Important points to note while rigging.

More information can be found in the Worker's Safety Handbook for Rigger and Signalman.

6. Operational Safety

6.1 Safety Considerations

This section highlights several safety considerations when operating cranes and hoists.

Visually check the operating environment to make sure that there are no new hazards which might affect the safe use of the crane.

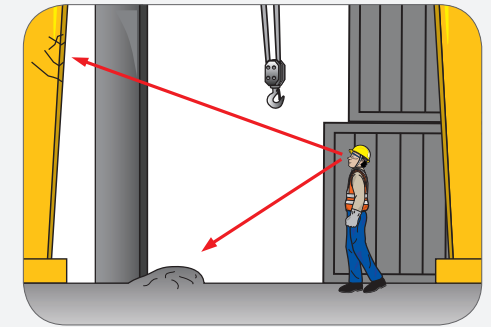

Do not make assumption. Ask if in doubt.

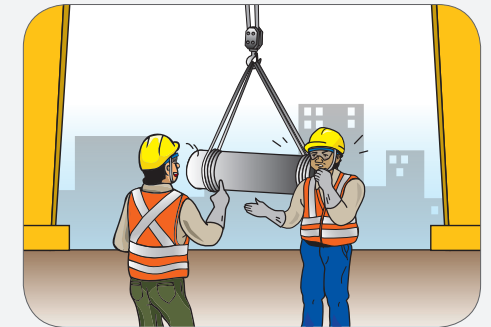

Do not operate the crane if not feeling well.

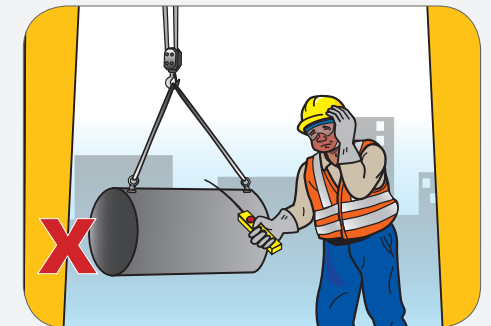

Do not operate the crane if it is locked out or tagged out (LOTO).

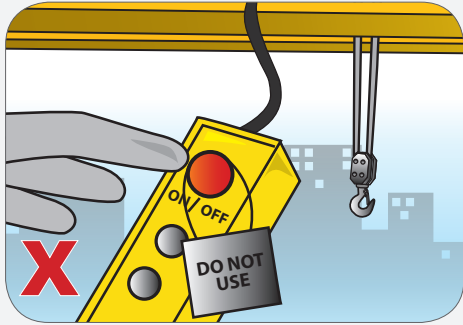

Do not overload crane or hoist.

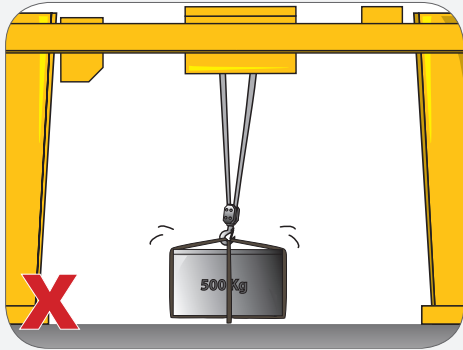

Do not use the hoist rope/chain as a sling.

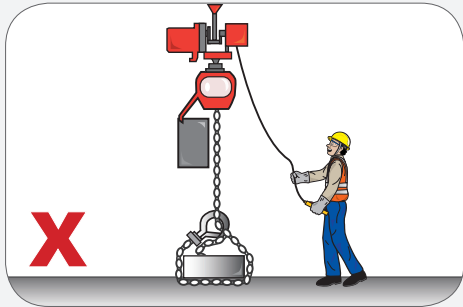

Do not lift a load from the side. Centre the crane directly over the load before hoisting to avoid swinging the load.

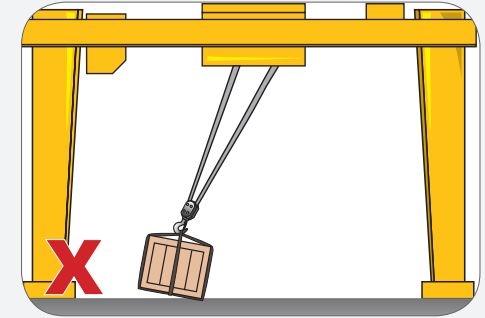

Do not ride on the load or allow others to do so.



Do not lift loads over people.



Make sure the load is properly secured before lifting.

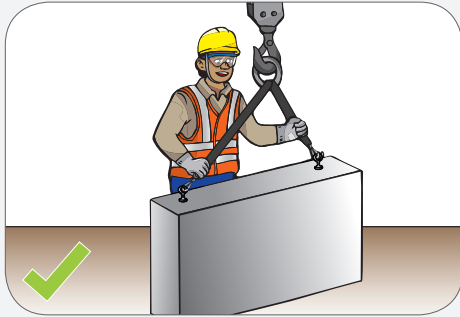

Do not multi-task when operating the crane.

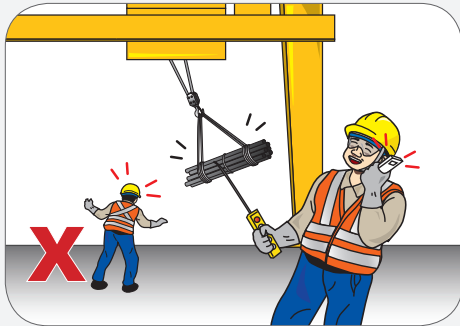

Do not operate the crane in a rushed manner.

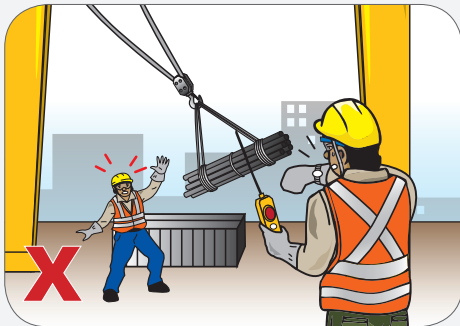

Communicate clearly between lifting team before and during lift.

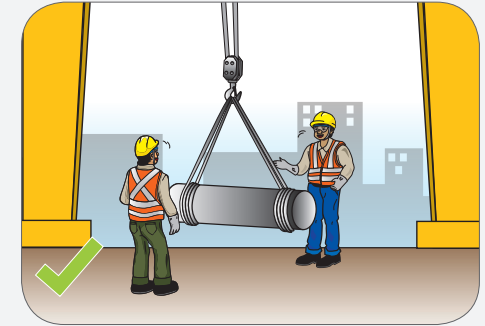

Use Tag Lines or Push/Pull Sticks to help control the load.

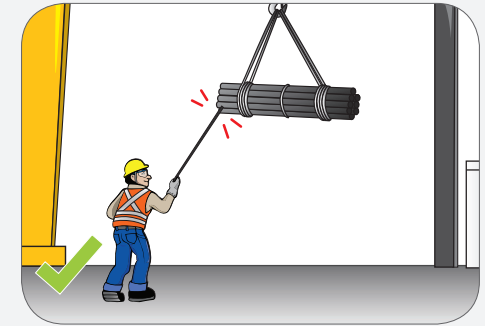

Do not use crane to pull out a jammed or stuck object.

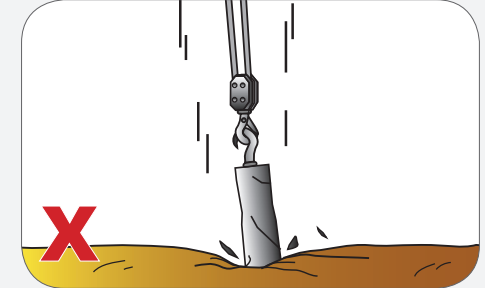

Ensure adequate clearances between cranes and fixed objects.

A ≥ 750mm

B ≥ 600mm

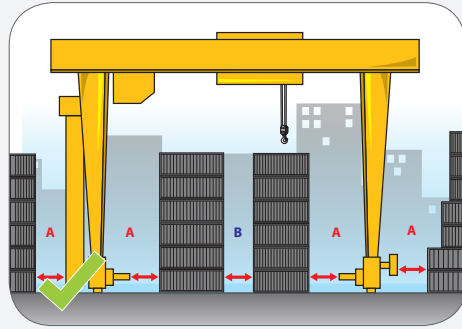

Do not leave suspended load overnight or unattended.



Figure 6: Safety considerations when operating cranes and hoists.

6.2 Tandem Lifting

When using more than one crane or with two hoists for tandem lifting operations, a competent person shall carefully plan out the operation in detail with a thorough lifting plan and emergency plans. The operation shall be carried out under proper supervision. The person supervising the operation shall fully understand the details of the operation and shall ensure that the operators understand the sequence and the hazards of the operation.

6.3 Maintenance

The employer must maintain a crane and its accessories in a condition that will not endanger an operator or other employee.

A preventive maintenance programme shall be established and the programme must be based on the manufacturer's recommendations and for the application as reviewed by a qualified person.

Please refer to SS 497 for further guidance.

7. Use of Special Lifting Attachments

The use of clamp, grab magnet, and vacuum as attachments are mainly used in heavy industry for mass production and in incinerator plant for waste management. The use of such attachments is complex. Should these attachments be used, users must refer to the manufacturers' operational and safety manual. Please see Figure 7 for Example of lifting steel plate.

Example of lifting steel plate

Example of lifting steel plate using lifting clamps.

- Metal sheets must be adequately secured as it could slide off in the process of lifting
- Special clamp must be use for steel plate lifting.
- Always lift only one plate at a time

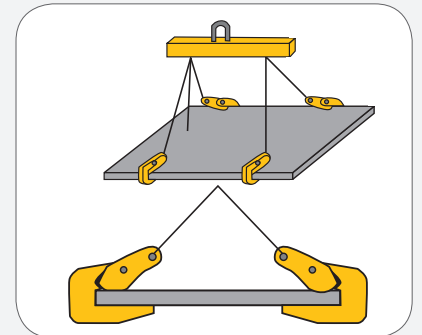
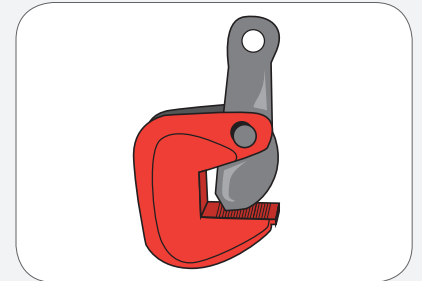

Figure 7: Example of lifting steel plate

8. Environmental Conditions

During outdoor operations, lifting operations can be affected by rain, thunderstorms and strong winds.

8.1 Rain

For all outdoor cranes / hoists, the equipment and all sensitive components should have been designed with the correct Ingress Protection (IP) enclosure and proper shelters.

8.2 Thunderstorms

- During thunderstorms, stop lifting operations immediately.

8.3 Strong Winds

- Cranes must never be used when wind speeds are beyond those recommended in the crane manufacturer's instructions.
- In the event of strong winds, stop all lifting operation and secure the gantry crane with a wind restraint device.

9. Documentation

The following three essential documents must be prepared and approved before the commencement of all lifting works:

- Risk Assessment;
- Safe Work Procedure; and
- Lifting Plan.

The crane operator must fully understand the above documents and follow them closely. If in doubt he/she must seek help from the supervisor.

10. References

- Workplace Safety and Health Act
- Workplace Safety and Health (General Provisions) Regulations
- Workplace Safety and Health (Risk Management) Regulations
- Workplace Safety and Health (Operation of Cranes) Regulations 2011
- Approved Code of Practice on Safe Lifting Operations in the Workplaces
- Approved Code of Practice SS497:2011 Code of Practice for Design, safe use and maintenance of gantry cranes, overhead travelling cranes and monorail hoists
- Approved Code of Practice SS567:2011 Code of Practice for Factory layout – Safety, health and welfare considerations
- Approved Code of Practice SS595:2014 Steel wire ropes for hoisting – Part 3: Code of Practice for the care, inspection and maintenance of steel wire ropes for hoisting
- Guidebook for Lifting Supervisors
- Worker's Safety Handbook for Rigger and Signalman

11. Annexes

Annex 1: Standard Hand Signals For Controlling Overhead and Gantry Cranes

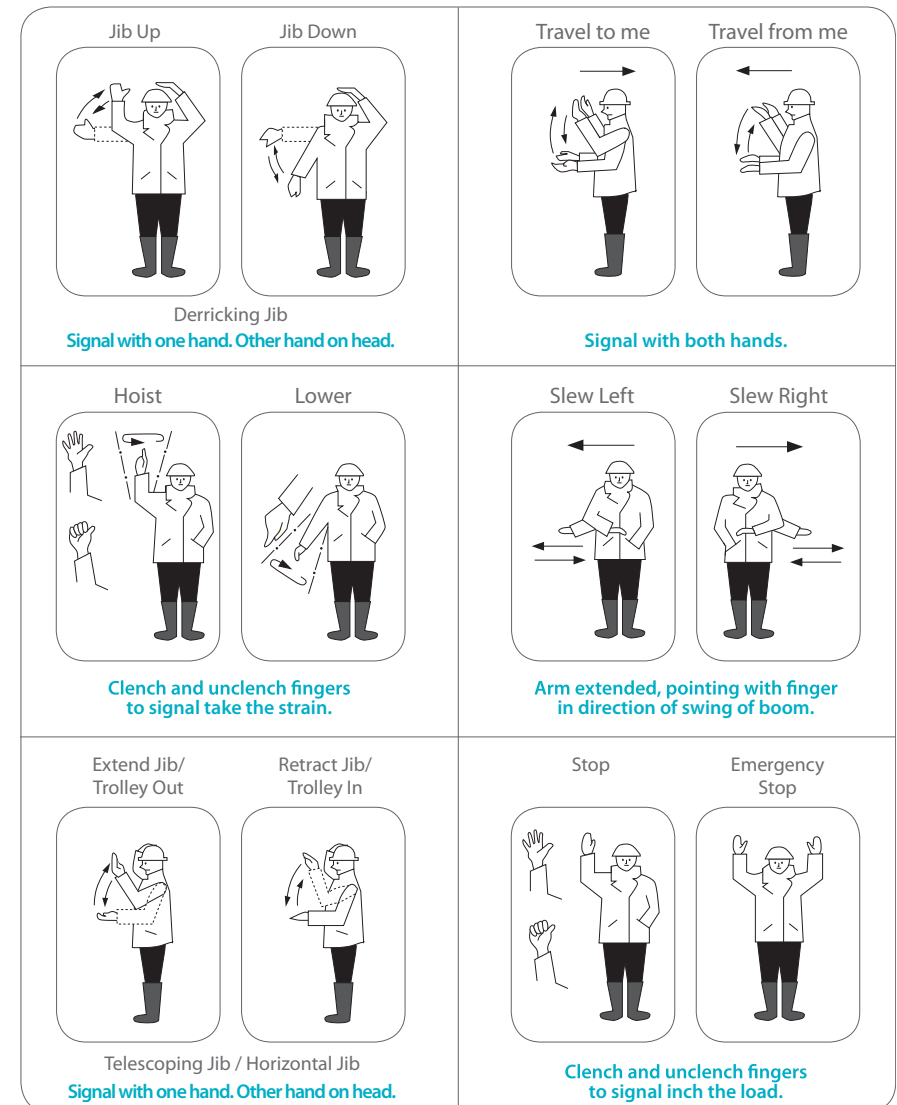

Annex 2: Lifting Appliances (LA) and Lifting Gear (LG)

Lifting appliances: includes pulley blocks, gin wheels, chain blocks or set of chain blocks.



Pulley Block



Chain Block

Lifting gear: any chain, rope, chain sling, webbing sling, rope sling, ring, hook, shackle, swivel or eyebolt and any cage or work platform used for carrying persons while suspended from the load line of a crane.



Chain Sling



Rope Sling



Webbing Sling



Lifting Ring

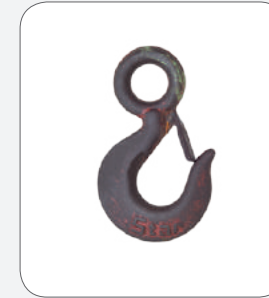

Lifting Hook



Lifting Shackle



Lifting Swivel

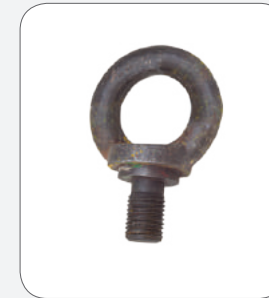

Eyebolt



Lifting Cage

12. Acknowledgements

The Workplace Safety and Health Council and Ministry of Manpower would like to thank the WSH Council (Overhead Gantry and Travelling Crane) Working Group and the WSH Council (National Crane Safety) Taskforce for their valuable assistance and involvement in the development of this pictorial guide.

Composition of the WSH Council (Overhead Gantry and Travelling Crane) Working Group

Mr Foong Kah-Choong (Chairman) - Helmsion Engineering Pte Ltd

Mr Poa Khay Hock - Excel Precast Pte Ltd

Mr Spincer Yeo C.W. – Interlift Sales Pte Ltd

Mr Loh Lee Bar - Keppel Shipyard Limited

Mr Jamie Pok – Konecranes Pte Ltd

Mr Goh Kim Teo – PSA Corporation Ltd

Mr Cathay Teo - SIA Engineering Company Ltd

Mr Johnny Cheng - Singapore Aero Engine Services Private Limited, SAESL

Mr Charles Tan - Ministry of Manpower

Mr Han Kin Sew - Workplace Safety and Health Council

Published in October 2016 by the Workplace Safety and Health Council in collaboration with the Ministry of Manpower.

All rights reserved. This publication may not be reproduced or transmitted in any form or by any means, in whole or in part, without prior written permission. The information provided in this publication is accurate as at time of printing. The Workplace Safety and Health Council does not accept any liability or responsibility to any party for losses or damage arising from following this publication.

This publication is available on the Workplace Safety and Health Council
Website: www.wshc.sg
Email: contact@wshc.sg

